



Thermocouple

Model ASTC-G

Thermocouple Model ASTC-G

High Temperature Thermocouple

Type B, R, S, K, J, N. Other types upon request

Tolerance Class 1 or 2 according to CEI EN60584-1, Standard o Special according to ASTM E230

Hot joint: insulated

Simple insulation by two-bores/four-bores ceramic or thermocouple insert in Oxide mineral (MgO)

Single or double ceramic protection

Ceramic sheath material: C610, C799

Ceramic sheath diameter from 6 to 20 mm

Sleeve material: Stainless steel 304, 310, 316, 446, Inconel600

Sleeve length upon request

Aluminum head connection

Inner connection with ceramic terminal block or temperature transmitter output 4..20 mA (HART protocol upon request)

Fix or sliding fittings

Option for sliding flange on the sleeve

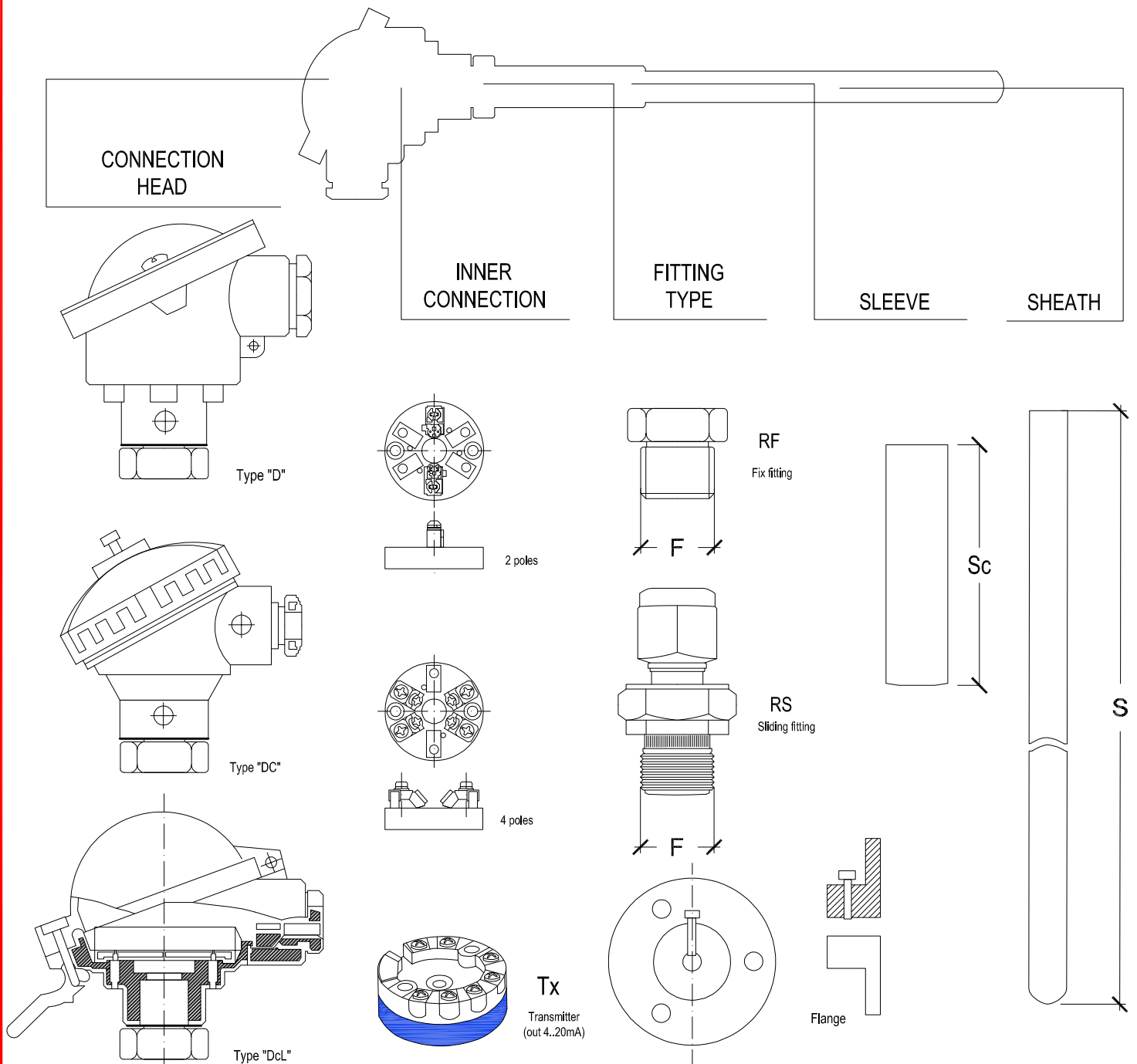

ASTC

G

a

Sg

Sc

MODEL	
Thermocouple B type	B
Thermocouple R type	R
Thermocouple S type	S
Thermocouple K type	K
Thermocouple N type	N
Thermocouple J type	J
Double TC B ($\varnothing > 2$ mm)	2B
Double TC R ($\varnothing > 2$ mm)	2R
Double TC S ($\varnothing > 2$ mm)	2S
Double TC K ($\varnothing > 2$ mm)	2K
Double TC N ($\varnothing > 2$ mm)	2N
Double TC J ($\varnothing > 2$ mm)	2J
Other type upon request	A

HOT JOINT	
Insulated hot joint	a

CERAMIC SHEATH DIAMETER	
\varnothing mm 6	6c
\varnothing mm 8	8c
\varnothing mm 10	10c
\varnothing mm 12	12c
\varnothing mm 15	15c
\varnothing mm 20	20c
Other diameter upon request	A

SLEEVE DIAMETER	
\varnothing mm 10	10
\varnothing mm 12	12
\varnothing mm 14	14
\varnothing mm 16	16
\varnothing mm 21,3	21
\varnothing mm 26,9	26
Other diameter upon request	A

SLEEVE MATERIAL	
Stainless steel 304	a04
Stainless steel 310	a10
Stainless steel 316	a16
Stainless steel 446	a46
INCONEL 600	i

TOLERANCE	
Class 1, CEI EN60584-1	1
Class 2, CEI EN60584-1	2
Class Special, ASTM E230	A
Class Standard, ASTM E230	B

CONNECTION HEAD	
DIN B	D
Screw cap DIN	Dc
Clips cap DIN	DcL

INNER CONNECTION	
2 poles	2
4 poles	4
Temperature transmitter (out 4...20mA)	Tx
HART temperature transmitter (out 4...20mA)	TH

CERAMIC SHEATH LENGTH (Sg)	
from mm 50	

SLEEVE LENGTH (Sc)	
from mm 50	

FITTING TYPE	
Fix fitting*	Rf
Sliding fitting	Rs
Sleeve flange	Fm

FITTING THREAD	
1/8" Gas male	1/8G
1/4" Gas male	1/4G
3/4" Gas male	3/4G
3/8" Gas male	3/8G
1/2" Gas male	1/2G
1/2" Npt male	1/2N
Other type upon request	A

ACCREDIA CALIBRATION	
	A



(*) If a fix fitting is required, indicate whether the length includes the thread or not

